



ASSEMBLY INSTRUCTION

FLOW CORNER

NO	HARDWARE LIST	QTY
(A)	 BOLTS M6x40	10PCS
(B)	 WASHER Ø6xØ19x1.2	10PCS
(C)	 ALLEN KEY M4x59	1PCS
NO	PART LIST	QTY
(1)	BODY 2 SEAT	1PCS
(2)	LEG 2 SEAT	1PCS
(3)	BODY 3 SEAT	1PCS
(4)	LEG 3 SEAT	1PCS

STEP 1

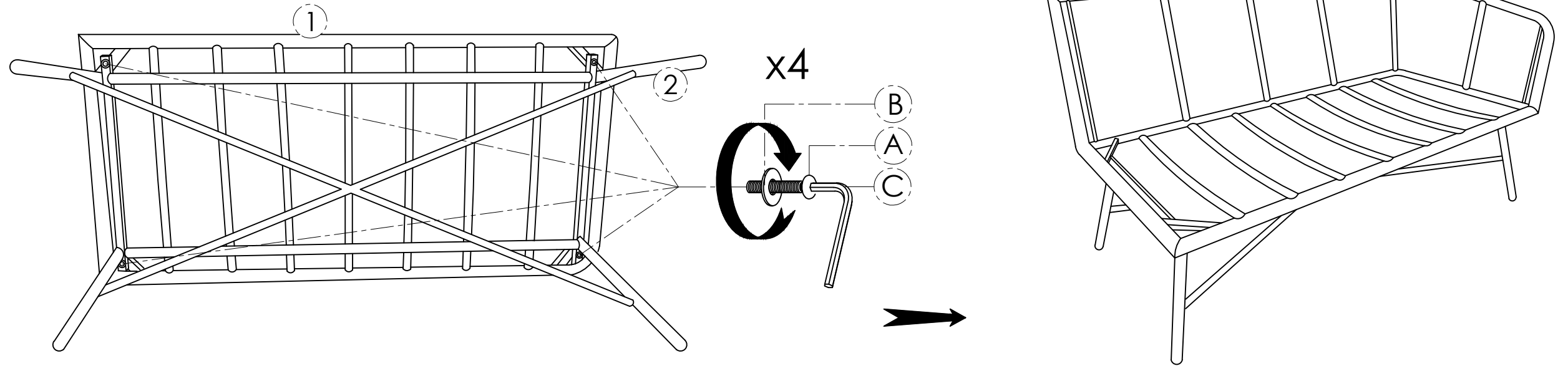

STEP 2

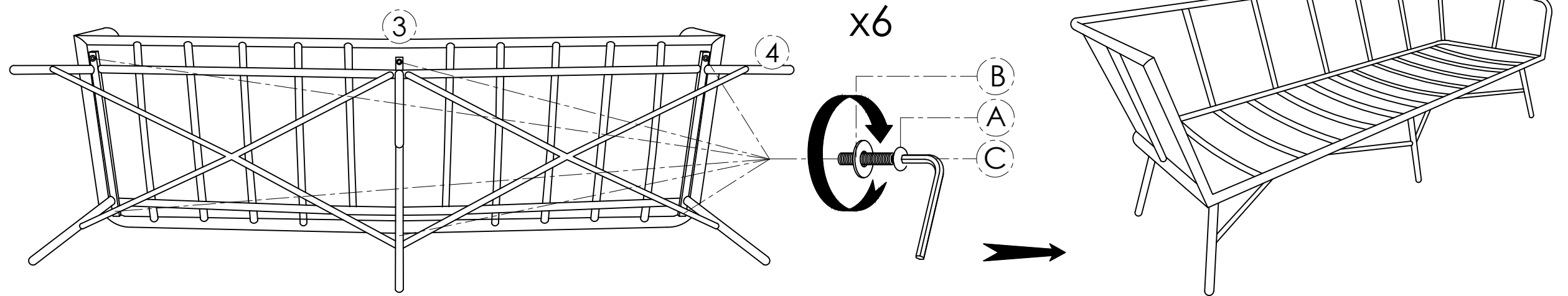

ASSEMBLY COMPLETE

